

# Compact fluorescent electronic

Replacing Chapter 4.63 Catalogue 2005/2006



HF-REGULATOR PL-T/C

**1-10V**

**recommended lamp pag. 4.4 and 4.10**

Dimensions in mm

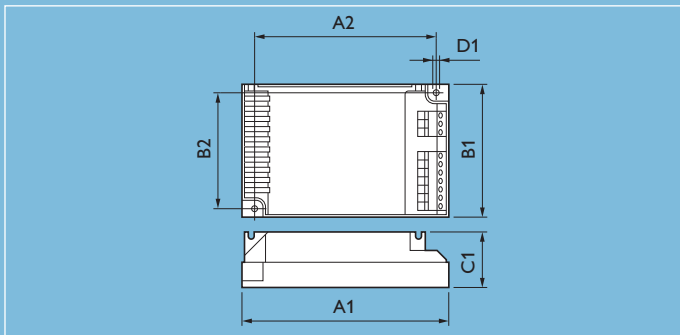

**PHILIPS**

# HF-REGULATOR PL-T/C

## Product description

Compact, lightweight, high-frequency electronic regulating ballast for PL-T and PL-C compact fluorescent lamps.

## Features and Benefits

- The lamp power can be regulated down to 3% (10-100% for HF-R 257 with Philips PL-T\*).
- Quick programmed start: 0.5 sec, flicker-free warm start, preheating the lamp electrodes; This enables the lamps to be switched on and off without reducing useful life. Ideal for areas with a high switching frequency.
- Stable lamp operation, striation-free operation.
- 1-10V control input (European standard).
- Up to 50% longer lamp life than with conventional ballasts.
- Up to 75% reduction in energy consumption can be achieved by using automatic lighting control systems.
- Smart power: constant light output independent of mains voltage fluctuations.
- Unit is protected against excessive mains voltages and incorrect connections.
- Automatic stop circuit is activated within five seconds in case of lamp failure (safety stop). Once the lamp has been replaced, the ballast resets automatically.

All Philips HF-REGULATOR electronic ballasts are equipped with  $\alpha$ -control. This is a dedicated integrated circuit that ensures independent control of each electrode and, in doing so, takes care that:

- lamp life is unaffected by dimming position
- lamp burning is stable in every dimming position; and
- energy savings, when dimming, are maximised.

## Applications

Typical areas of application include:

- Installations with daylight linking and/or movement detection (for energy savings)
- Installations with remote control systems (personal scene setting)
- Installations with emergency back-up, according to VDE 0108.

Examples:

- Office buildings: insurance companies, banks, government ministries
- Cellular offices, open plan offices, corridors and lobbies
- Conference rooms, lecture theatres
- Department stores, shops, supermarkets and malls
- Hotels, restaurants and bars
- Cinemas, museums
- Hospitals
- Schools.

## Philips quality

This applies optimum quality with respect to:

- System supplier  
As manufacturers of lamps, electronic control gear and lighting control equipment, Philips ensures that, from the earliest development stage, optimum performance is maintained.
- International standards  
Philips HF electronic regulating ballasts comply with all relevant international rules and regulations.

\*light regulation of comparable lamps from other manufacturers may deviate.

	A1	A2	B1	B2	C1	D1
1 Lamp	123	111	79	67	33	4,5
2 Lamps	123	111	79	67	33	4,5

## Compact fluorescent electronic

## HF-REGULATOR PL-T/C

### Compliances and approvals

• RFI<30 MHz:	EN 55015*
• RFI>30 MHz:	EN 55022 Limit B
• Harmonics:	EN 61000-3-2
• Immunity:	EN 61547
• Safety:	EN 61347-2-3
• Performance:	EN 60929
• Vibration & bump tests:	EN 60068-2-6-FC EN 60068-2-29-Eb
• Quality standard:	ISO 9001
• Environmental standard:	ISO 14001
• Approval marks:	ENEC VDE-EMV
• Temp. declared thermally protected	EN 61347-1 
• CE marking	

\* Tested with ballast functional ground connected to earth.

### Technical data for installation

Mains operation	
Rated mains voltage	220-240 V
With tolerances for safety: +/- 10%	198-264 V
Tolerances for performance +6%-8%	202-254 V
Mains frequency	50/60 Hz
Operating frequency	> 42 kHz
Power factor	0.95 at 100% power
Power factor HF-R 118 PL-T/C	0.90 at 100% power
Smart power: with AC mains voltage fluctuations,	202V - 254 V
Luminous flux varies by + 2% max.	

### DC voltage operation (during emergency back-up)

Required battery voltage for guaranteed ignition	198V - 254V
Required battery voltage for burning lamps	176V - 254V
Nominal light output is obtained at a voltage of	220V - 240V

### Inrush current

Ballast	Lamp	Max. quantity of ballasts per Miniature Circuit Breaker Type B16 A	Inrush current 1/2 value time at typical mains impedance	
HF-R 118 PL-T/C	PL-T/C 18W	28		27A/250µs
HF-R 218 PL-T/C	PL-T/C 18W	28		27A/250µs
HF-R 1 26-42 PL-T/C	PL-T/C 26W	28		27A/250µs
HF-R 2 26-42 PL-T/C	PL-T/C 26W	28		27A/250µs
HF-R 1 26-42 PL-T/C	PL-T 32W	28		27A/250µs
HF-R 2 26-42 PL-T/C	PL-T 32W	12		45A/400µs
HF-R 1 26-42 PL-T/C	PL-T 42W	28		27A/250µs
HF-R 2 26-42 PL-T/C	PL-T 42W	12		45A/400µs
HF-R 157 PL-T	PL-T 57W	12		45A/250µs
HF-R 257 PL-T	PL-T 57W	12		45A/250µs

### Notes:

- For continuous DC application, an external fuse should be used in the luminaire.
- Continuous low DC voltages (<198V) can influence the lifetime of the ballast.

Earth leakage current	< 0.5 mA per ballast
Maximum number of ballasts which can be connected to one Residual Current Detector of 30 mA	30
Overvoltage protection	48 hrs at 320 V AC 2 hrs at 350 V AC
Automatic restart after lamp replacement or voltage dip	Yes

### Mains current at 230V

Ballast	Lamp A	Input current
HF-R 118 PL-T/C	PL-T/C 18W	0.09
HF-R 218 PL-T/C	PL-T/C 18W	0.17
HF-R 1 26-42 PL-T/C	PL-T/C 26W	0.13
HF-R 1 26-42 PL-T/C	PL-T 32W	0.17
HF-R 1 26-42 PL-T/C	PL-T 42W	0.21
HF-R 2 26-42 PL-T/C	PL-T/C 26W	0.25
HF-R 2 26-42 PL-T/C	PL-T 32W	0.33
HF-R 2 26-42 PL-T/C	PL-T 42W	0.41
HF-R 157 PL-T	PL-T 57W	0.27
HF-R 257 PL-T	PL-T 57W	0.53

### Conversion table for max. quantities of ballasts on other types of Miniature Circuit Breakers

MCB Type	Relative quantity of ballasts
B	100%(see table on the left)
B	63%
C	170%
C	104%
L, I	108%
L, I	65%
G, U, II	212%
G, U, II	127%
K, III	254%
K, III	154%

# Compact fluorescent electronic

# HF-REGULATOR PL-T/C

**Insulation resistance test** 500V DC from Line/Neutral to Earth (not between Line and Neutral)  
 Note: Ensure that the neutral is reconnected again after the above mentioned test is carried out and before the installation is put into operation.

**Lamp wiring** The use of 500V rated components and wiring is advised for PL-T 32W, 42W and 57W types.

**Ignition time** Typical 0.5 sec.

**Advised maximum cable capacity for optimum performance and EMI Suppression** Max. 30 pF: between two sets of lamp wires (each set of lamp wires is connected to one electrode of the lamp)  
 Max. 75 pF: between one set of lamp wires (connected to one electrode of the lamp) and earth. Care has to be taken for symmetrical wiring

### Control input

**Control voltage** 1 – 10V DC

**Protected against accidental mains voltage connection** Yes

**Regulating level (lamp power)** 3 to 100%  
 The control input complies with EN 60929 (Amendment 1, Annex E) and is compatible with Philips lighting control equipment.

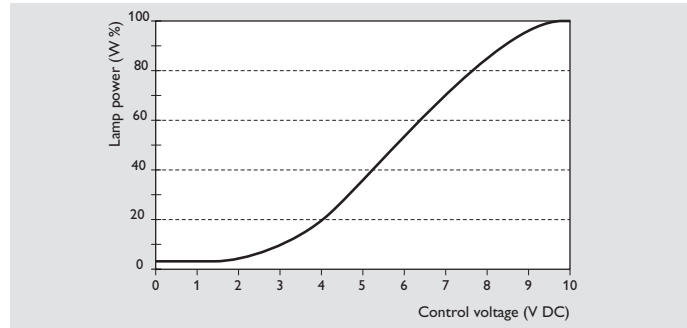

Relationship between lamp power and control voltage

### Technical data for design and mounting in fixtures

**Temperatures**  
 Temperature range to ignite lamp +10 °C to +50 °C  
 With ignition aid  
 Stable lamp operation assured > 15 °C  
 Striation possible < 15 °C  
 Max t case 75 °C

**Earthing** Earthing of the HF ballast in a luminaire is necessary for EMC (electromagnetic compatibility)

**Class II luminaires** This application is not advisable; only with extensive tests on luminaires can the correct operation be verified

**Hum and noise level** Inaudible

Permitted humidity is tested according to EN 61347 par.11. Note that no moisture or condensation may enter the ballast.

### Technical data in relation to energy saving

Lamp	Qty of lamps	Ballast	System		Lamp			CELMA class.
			power*	Efficacy*	Power*	Efficacy*	Lumen*	
			W	lm/W	W	lm/W	lm	EEI
PL-C 18W	1	HF-R 118 PL-T/C	20	60	16.5	73	1200	A1
PL-T 18W	1	HF-R 118 PL-T/C	20	60	16.5	73	1200	A1
PL-C 18W	2	HF-R 218 PL-T/C	39	62	16.5	73	1200	A1
PL-T 18W	2	HF-R 218 PL-T/C	39	62	16.5	73	1200	A1
PL-C 26W	1	HF-R 126-42 PL-T/C	30	60	24	75	1800	A1
PL-T 26W	1	HF-R 126-42 PL-T/C	30	60	24	75	1800	A1
PL-C 26W	2	HF-R 226-42 PL-T/C	56	64	24	75	1800	A1
PL-T 26W	2	HF-R 226-42 PL-T/C	56	64	24	75	1800	A1
PL-T 32W	1	HF-R 126-42 PL-T/C	39	62	32	75	2400	A1
PL-T 32W	2	HF-R 226-42 PL-T/C	72	67	32	75	2400	A1
PL-T 42W	1	HF-R 126-42 PL-T/C	48	67	43	74	3200	A1
PL-T 42W	2	HF-R 226-42 PL-T/C	93	69	43	74	3200	A1
PL-T 57W	1	HF-R 157 PL-T	63	68	56	77	4300	A1
PL-T 57W	2	HF-R 257 PL-T	119	70	56	77	4300	A1

\* At 100%

# Compact fluorescent electronic

# HF-REGULATOR PL-T/C

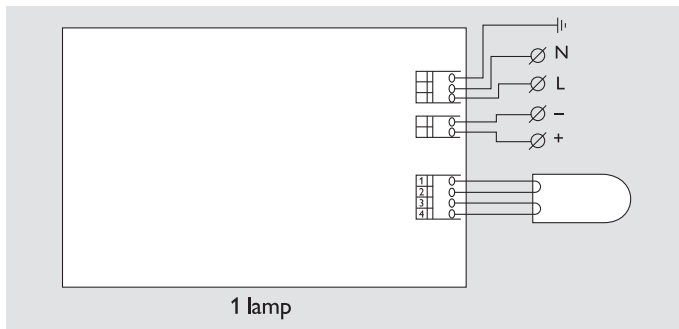

1 lamp

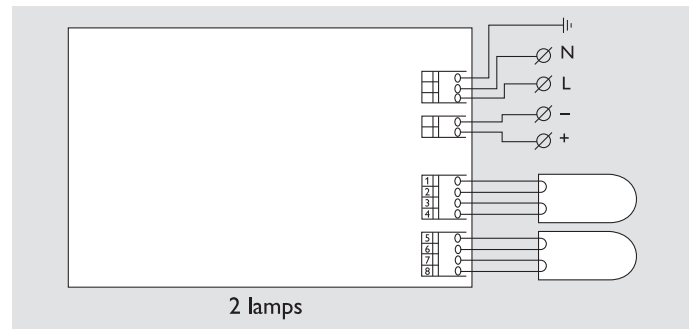

2 lamps

Wiring diagrams

Connecting wiring is greatly simplified through use of insert contacts:

Wire cross-section:		
Mains connector	[Orange]	0.5 mm – 1.5 mm <sup>2</sup>
Control connector	[Blue]	0.5 mm – 1.5 mm <sup>2</sup>
Lamp(s) connector	[Gray]	0.5 mm – 1.5 mm <sup>2</sup>

## Notes

- For optimum performance, note that wires from connection 1 and 2 should be kept short and equal in length.
- Keep lamp wiring as short as possible; do not bunch wires from terminals 1 & 2 with those from terminals 3 & 4 (1-lamp ballasts), or wires from terminals 3, 4, 5 & 6 with those from terminals 1, 2, 7 & 8 (2-lamp ballasts).
- lp-lp between lamp wires  
Typical capacitance 1m wires close together (spacing 0.5 mm) 46 pF  
Typical capacitance 0.5m wires close together (spacing 0.5 mm) 23 pF  
lp-lg between lamp wires and ground  
Typical capacitance 1 m wires close to ground (spacing 0.5 mm) 72 pF  
Typical capacitance 0.5 m wires close to ground (spacing 0.5 mm) 38 pF
- Data is based on a mains supply with an impedance of 400 mΩ (equal to 15 m cable of 2.5 mm<sup>2</sup> and another 20 m to the middle of the power distribution), under worst case conditions. With an impedance of 800 mΩ the number of ballasts can be increased by 10%.
- Measurements will be verified in real installations, therefore data are subject to change.
- In some cases the maximum number of ballasts is not determined by the MCB, but by the maximum electrical load of the lighting installation.
- Note that the maximum number of ballasts is based on the assumption that these are all switched on the same moment, i.e. by a wall switch.
- Measurements were carried out on single-pole MCB's. For multi-pole MCB's it is recommended to reduce the number of ballasts by 20%.

## Ordering and packaging data

Ballast	1 Piece		Bulk packing					EAN code	EOC
	EAN code	Weight	Qty	Dimensions	Volume	Weight			
		kg	pcs	l x w x h cm	m <sup>3</sup>	gross kg			
HF-R 118 PL-T/C	8711 500 908674	0.195	12	25.5x24.5x8.2	0.01	3.0	8711 500 908681	908674 30	
HF-R 218 PL-T/C	8711 500 908698	0.205	12	25.5x24.5x8.2	0.01	3.0	8711 500 908759	908698 30	
HF-R 126-42 PL-T/C	8711 500 908666	0.195	12	25.5x24.5x8.2	0.01	3.0	8711 500 908773	908666 30	
HF-R 226-42 PL-T/C	8711 500 908680	0.225	12	25.5x24.5x8.2	0.01	3.0	8711 500 908797	908680 30	
HF-R 157 PL-T	8711 500 908827	0.220	12	25.5x24.5x8.2	0.01	3.0	8711 500 908810	908827 30	



3222 635 56281  
04/2006  
Printed in the Netherlands  
Data subject to change